

ROTHENBERGER

SUPERTRONIC 2000 - 1 1/4"



www.cscindustrial.com
Ph: 1-866-496-7268
Fax: 1-915-760-4832
5970 Silver Springs Dr.
El Paso, TX 79912

7.1240 7.1245
7.1250 7.1251



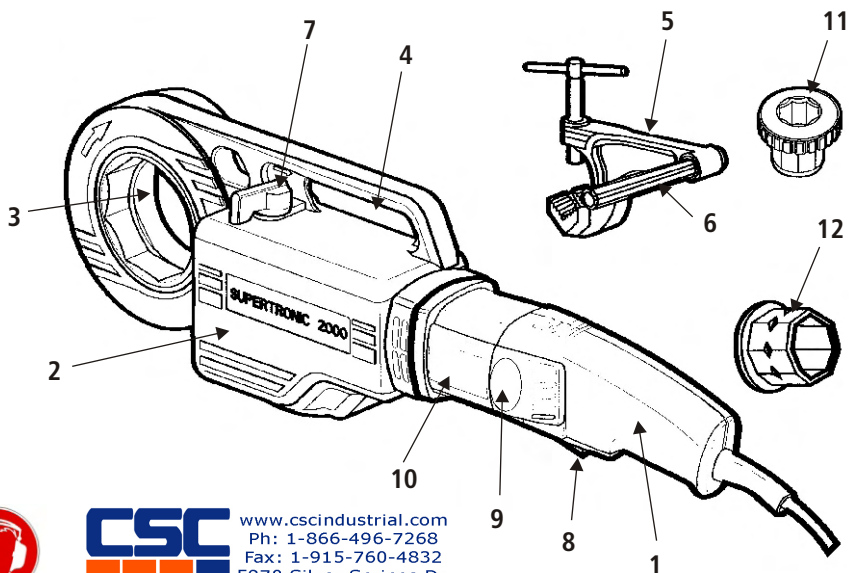

CSC
Industrial Corporation

www.cscindustrial.com
Ph: 1-866-496-7268
Fax: 1-915-760-4832
5970 Silver Springs Dr.
El Paso, TX 79912

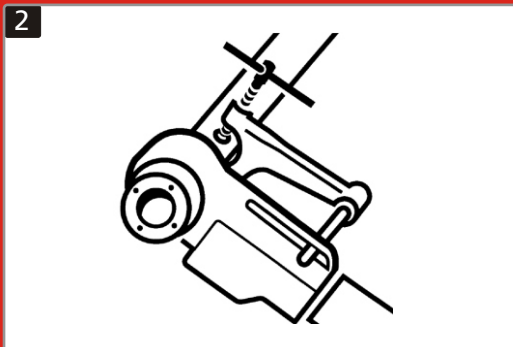
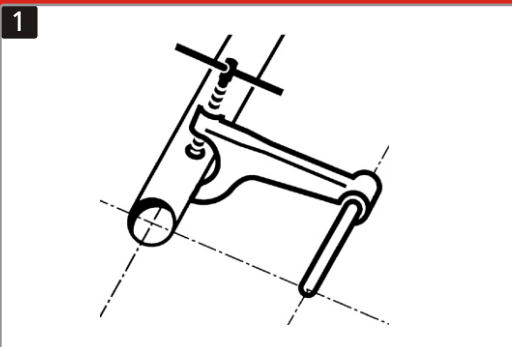

Technical data

	<u>¼" - 2"</u>	<u>¼" - 1 ¼"</u>
Threading capacity:	1/4" to 2"	1/4" to 1.1/4"
Type of thread:	BSPT (Right, Left) NPT	BSPT (Right, Left) NPT
Thread taper:	1/16	1/16
Threading speed (1/min):	25 to 15	25 to 15
Fast reverse speed (1/min):	58	58
Electric current:	230 V (110 V) 50/60 Hz	230 V (110 V) 50/60 Hz
Absorbed power:	1.010 W (900 W)	1.010 W (900 W)
ON switch:	non-blocking	non-blocking
Machine weight:	6 Kgs	6 Kgs
Machine size:	580 x 95 x 140 mm	580 x 95 x 140 mm
Tube fastener weight:	1,6 kg	1,6 kg
Weight complete set:	17 kg	16,4 kg
Lw / Lp	100 dBA / 87 dBA	100 dBA / 87 dBA
Vibration	< 2,5m/s ²	< 2,5m/s ²
R (DIN 2999, BSPT), NPT/API, G (DIN ISO 228, DIN 259, BSPP) NPSM, Pg, M, BSW, UNC		

Proper usage

This device may only be used correctly as described.

Special safety instructions

It is essential to read and understand the general safety instructions in the Safety appendix (Page 52 and following)!

Do not thread without using the tube clamp. The tube clamp should be used even when threading the smallest sizes.

Check that the tube clamp is perfectly mounted. If the tube is not fastened correctly, the machine would rotate on the threading head, with the consequent risk of injury to the operator. The tube fastening bolt is left loose inside the case cover and should be screwed into its corresponding hole.

Check condition of ON switch. When released of pressure, check that the ON switch unblocks automatically.

Use of extension cables. Check that the cable is as thick and as short as possible. The extension cable should be for more than 15 Amp and not longer than 30 metres.

Do not thread without abundant and continuous lubrication. Good lubrication will prolong the life of your machine and threading heads. It will also improve threading quality.

Always thread at working speed. Threading from right to left should be done at the working speed indicated on the reversing gear lever in direction of the arrow. Fast speed will only be used to unscrew the threading head from tube.

Do not change speeds during the threading operation. For left thread, insert the threading head at the opposite end of the machine and maintain rotation in work direction. When the threading operation has been completed, stop the machine and change gears to initiate reverse movement and free the tube.



www.cscindustrial.com
Ph: 1-866-496-7268
Fax: 1-915-760-4832
5970 Silver Springs Dr.
El Paso, TX 79912

A - Overview

- | | | | |
|---|--------------------------|----|------------------------------|
| 1 | Motor | 7 | Reverse speed lever |
| 2 | Gearbox | 8 | ON switch |
| 3 | Head housing | 9 | Brush housing |
| 4 | Tube fastener adjustment | 10 | Machine identification plate |
| 5 | Tube fastener | 11 | Adapter monoblok.1/4"-1.1/4" |
| 6 | bolt | 12 | Adapter euroblok.1/4"-1.1/4" |

B - Operating instructions

Fasten the tube clamp securely and check that the machine's anchor bolt is parallel to the tube to be threaded (**Fig. 1**). The bolt should extend over the end of the tube by approximately 1 or 1.5 cm.

Choose the threading head according to your needs and mount it in the octagonal coupling of the machine. Fit the adapter first, when using a 1.1/4" head. For right thread, insert the threading head at the front of the machine. For left thread, insert the threading head at opposite end of the machine.

When using the adapter, this should be directly inserted in the octagonal coupling of the machine on the same in which the threading head has been inserted (right thread: front side; left thread: opposite side) and secured by its threaded cap.

To insert the head into the adapter, move the mobile part of the latter counter-clockwise until it is completely inserted. This will spring back securing the head. To remove it, proceed in likewise manner.

Next insert the machine in the tube and make sure that it is securely guided into its housing by the tube clamp bolt (**Fig. 2**).

Check that the reverse gear lever is correctly in place (arrow in working direction). Press the electric switch with your right hand. Rotation will start immediately. Now the head should be moved towards the tube to start the threading process by pressing on the machine.

As soon as threading has begun, the head should be constantly and abundantly lubricated with threading oil Rothenberger (**Fig. 3**).

Once the appropriate threading length has been achieved (the tube of the threading head should never overhang in a normal thread), stop the motor. Change the position of the reverse gear lever and start the motor. The machine will begin to unscrew the head and the tube will become free (**Fig. 4**).

ATTENTION! Fast speed must only be used to unscrew the head. Never thread on fast speed!

Maintenance

Cable and plug. Both the cable and plug should be in optimum condition. Check them at regular intervals.

ON switch. Check that the machine switch unblocks automatically when finger pressure is released. In case of any anomaly, replace immediately with a new one.

Brushes. Check frequently for brush wear and perfect contact with rotor. Change brushes when their length is 1/3 of original length. Use original Rothenberger brushes.

Motor and rotor. The carbon dust accumulated in the motor and brush housing should be removed every 100 hours. The motor's rotor should be permanently clean with a uniform surface (light bronze colour).

Threading heads. Check that there are no damaged teeth on the head to be used, as thread quality could be seriously deteriorated. Keep clean of swarf to achieve top quality threading and longer life.

Gear box. Change grease every 500 operating hours. After dismantling the machine, oil all mechanisms to eliminate old grease. Remove parts with dry compressed air and apply new grease with clean hands. Do not use any dissolvents. Approximately 300 gr. of grease is needed for a correct lubrication. An excessive amount of grease is not recommended as it can increase the temperature of the machine. Grease type: LGMT2 by SKF or similar. We recommend that this operation be carried out by an authorized after-sales service.

Tube fastener (clamp). Check that the tube fastener clamp is in good condition. Replace when tube displacement occurs.

Troubleshooting

Insufficient power

- Make sure that extension cable is not too long or that it does not have insufficient section
- Make sure that the right working speed is being used.
- Tube clamp must be well secured (bolt parallel to tube).
- Check operating condition of threading heads.
- Apply plenty and continuous lubrication to threading heads.
- Make sure that the tube can be screwed.

Off-centre threading

- Check position of tube fastener (shaft parallel to tube).
- Check condition and quality of tube.

Insufficient thread length

- Check correct positioning of tube fastener.
- Make sure that there is no obstruction between the machine and the tube fastener.

Poor thread quality

- Check condition of teeth.
- Check that there is continuous and abundant lubrication.
- Check quality of tube.
- Check quality of threading oil (use Rothenberger oil).

Incorrect adjustment of threading head

- Use the adapter for appropriate sizes (up to 1.1/4")
- Check that the appropriate threading head is being used (Rothenberger, serie 600 or equivalent).

Locked Shift lever

- Move the machine slightly upwards and downwards.

Accessories

The relevant accessories and an order form can be found from Page 84 onwards.

Disposal

Components of the unit are recyclable material and should be put to recycling. For this purpose registered and certified recycling companies are available. For an environmentalfriendly disposal of the non-recyclable parts (e.g. electronic waste) please contact your local waste disposal authority.



www.cscindustrial.com
Ph: 1-866-496-7268
Fax: 1-915-760-4832
5970 Silver Springs Dr.
El Paso, TX 79912

GENERAL SAFETY RULES

WARNING! Read all instructions. Failure to follow all instructions listed below may result in electric shock, fire and/or serious injury. The term “power tool” in all of the warnings listed below refers to your mains operated (corded) power tool or battery operated (cordless) power tool.

SAVE THESE INSTRUCTIONS.

1) Work area

- a) **Keep work area clean and well lit.** Cluttered and dark areas invite accidents.
- b) **Do not operate power tools in explosive atmospheres, such as in the presence of flammable liquids, gases or dust.** Power tools create sparks which may ignite the dust or fumes.
- c) **Keep children and bystanders away while operating a power tool.** Distractions can cause you to lose control.

2) Electrical safety

- a) **Power tool plugs must match the outlet. Never modify the plug in any way. Do not use any adapter plugs with earthed (grounded) power tools.** Unmodified plugs and matching outlets will reduce risk of electric shock.
- b) **Avoid body contact with earthed or grounded surfaces such as pipes, radiators, ranges and refrigerators.** There is an increased risk of electric shock if your body is earthed or grounded.
- c) **Do not expose power tools to rain or wet conditions.** Water entering a power tool will increase the risk of electric shock.
- d) **Do not abuse the cord. Never use the cord for carrying, pulling or unplugging the power tool. Keep cord away from heat, oil, sharp edges or moving parts.** Damaged or entangled cords increase the risk of electric shock.
- e) **When operating a power tool outdoors, use an extension cord suitable for outdoor use.** Use of a cord suitable for outdoor use reduces the risk of electric shock.

3) Personal safety

- a) **Stay alert, watch what you are doing and use common sense when operating a power tool. Do not use a power tool while you are tired or under the influence of drugs, alcohol or medication.** A moment of

inattention while operating power tools may result in serious personal injury.

- b) **Use safety equipment. Always wear eye protection.** Safety equipment such as dust mask, nonskid safety shoes, hard hat, or hearing protection used for appropriate conditions will reduce personal injuries.
 - c) **Avoid accidental starting. Ensure the switch is in the off position before plugging in.** Carrying power tools with your finger on the switch or plugging in power tools that have the switch on invites accidents.
 - d) **Remove any adjusting key or wrench before turning the power tool on.** A wrench or a key left attached to a rotating part of the power tool may result in personal injury.
 - e) **Do not overreach. Keep proper footing and balance at all times.** This enables better control of the power tool in unexpected situations.
 - f) **Dress properly. Do not wear loose clothing or jewellery. Keep your hair, clothing and gloves away from moving parts.** Loose clothes, jewellery or long hair can be caught in moving parts.
 - g) **If devices are provided for the connection of dust extraction and collection facilities, ensure these are connected and properly used.** Use of these devices can reduce dust related hazards.
- ### 4) Power tool use and care
- a) **Do not force the power tool. Use the correct power tool for your application.** The correct power tool will do the job better and safer at the rate for which it was designed.
 - b) **Do not use the power tool if the switch does not turn it on and off.** Any power tool that cannot be controlled with the switch is dangerous and must be repaired.
 - c) **Disconnect the plug from the power source before making any adjustments, changing accessories, or storing power tools.** Such preventive safety measures reduce the risk of starting the power tool accidentally.
 - d) **Store idle power tools out of the reach of children and do not allow persons unfamiliar with the power tool or these instructions to operate the power tool.** Power tools are dangerous in the hands of untrained users.
 - e) **Maintain power tools. Check for misalignment or binding of moving parts, breakage of parts and any other condition**

that may affect the power tools operation. If damaged, have the power tool repaired before use. Many accidents are caused by poorly maintained power tools.

- f) **Keep cutting tools sharp and clean.** Properly maintained cutting tools with sharp cutting edges are less likely to bind and are easier to control.
- g) **Use the power tool, accessories and tool bits etc., in accordance with these instructions and in the manner intended for the particular type of power tool, taking into account the working conditions and the work to be performed.** Use of the power tool for operations different from those intended could result in a hazardous situation.

5) Battery tool use and care

- a) **Ensure the switch is in the off position before inserting battery pack.** Inserting the battery pack into power tools that have the switch on invites accidents.
- b) **Recharge only with the charger specified by the manufacturer.** A charger that is suitable for one type of battery pack may create a risk of fire when used with another battery pack.
- c) **Use power tools only with specifically designated battery packs.** Use of any other battery packs may create a risk of injury and fire.
- d) **When battery pack is not in use, keep it away from other metal objects like paper clips, coins, keys, nails, screws, or other small metal objects that can make a connection from one terminal to another.** Shorting the battery terminals together may cause burns or a fire.
- e) **Under abusive conditions, liquid may be ejected from the battery; avoid contact.** If contact accidentally occurs, flush with water. If liquid contacts eyes, additionally seek medical help. Liquid ejected from the battery may cause irritation or burns.
- ## 6) Service
- a) **Have your power tool serviced by a qualified repair person using only identical replacement parts.** This will ensure that the safety of the power tool is maintained.



www.cscindustrial.com
Ph: 1-866-496-7268
Fax: 1-915-760-4832
5970 Silver Springs Dr.
El Paso, TX 79912

INDICATIONS GÉNÉRALES DE SÉCURITÉ

ATTENTION ! Lire toutes les indications. Le non-respect des instructions indiquées ci-après peut entraîner un choc électrique, un incendie et/ou de graves blessures sur les personnes. La notion d'« outil électroportatif » mentionnée par la suite se rapporte à des outils électriques raccordés au secteur (avec câble de raccordement) et à des outils électriques à batterie (sans câble de raccordement). **GARDER PRÉCIEUSEMENT CES INSTRUCTIONS DE SÉCURITÉ.**

1) Place de travail

- a) **Maintenez l'endroit de travail propre et bien éclairé.** Un lieu de travail en désordre ou mal éclairé augmente le risque d'accidents.
- b) **N'utilisez pas l'appareil dans un environnement présentant des risques d'explosion et où se trouvent des liquides, des gaz ou poussières inflammables.** Les outils électroportatifs génèrent des étincelles risquant d'enflammer les poussières ou les vapeurs.
- c) **Tenez les enfants et autres personnes éloignés durant l'utilisation de l'outil électroportatif.** En cas d'inattention vous risquez de perdre le contrôle sur l'appareil.

2) Sécurité relative au système électrique

- a) **La fiche de secteur de l'outil électroportatif doit être appropriée à la prise de courant. Ne modifiez en aucun cas la fiche. N'utilisez pas de fiches d'adaptateur avec des appareils avec mise à la terre.** Les fiches non modifiées et les prises de courant appropriées réduisent le risque de choc électrique.
- b) **Évitez le contact physique avec des surfaces mises à la terre tels que tuyaux, radiateurs, fours et réfrigérateurs.** Il y a un risque élevé de choc électrique au cas où votre corps serait relié à la terre.
- c) **N'exposez pas l'outil électroportatif à la pluie ou à l'humidité.** La pénétration d'eau dans un outil électroportatif augmente le risque d'un choc électrique.
- d) **N'utilisez pas le câble à d'autres fins que celles prévues, n'utilisez pas le câble pour porter l'appareil ou pour l'accrocher ou encore pour le débrancher de la prise de courant. Maintenez le câble éloigné des sources de chaleur, des parties grasses, des**

OPTIONAL

7.1278 SUPERTRONIC 1 1/4"
7.1274X SUPERTRONIC 2000



7.1280



7.1272



7.1273



7.1271



6.5600



6.5010 5l RONOL
6.5008 600ml RONOL



6.5015 5l RONOL SYN
6.5013 600ml RONOL SYN



6.5080



www.rothenberger.com



www.rothenberger.com



www.rothenberger.com

9.0100

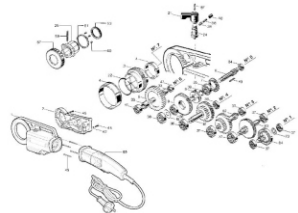

OPTIONAL

Zubehör und Ersatzteile / Accessories and spare parts

Bestellen Sie Ihre Zubehör- und Ersatzteile bei Ihrem Fachhändler
Order your accessories and spare parts from your specialist retailer



www.cscindustrial.com
Ph: 1-866-496-7268
Fax: 1-915-760-4832
5970 Silver Springs Dr.
El Paso, TX 79912

Stempel / Stamp

Kunde / Anschrift Customer / address	
Kunden Nr. / customer no.	
Bestell Nr. / Order no.	
Ansprechpartner Contact person	
Tel.:	

Ihre Bestellung
Your order

Artikel Nr. / Article no.	Menge / Quantity	Bezeichnung / Description	Preis / Price

.....
Datum / Date

.....
Unterschrift / Signature



Notes



www.cscindustrial.com
Ph: 1-866-496-7268
Fax: 1-915-760-4832
5970 Silver Springs Dr.
El Paso, TX 79912