

MOTOR AND TRANSMISSION ASSEMBLY
13905 — 220 V., 3 PHASE
13906 — 380-440 V., 3 PHASE

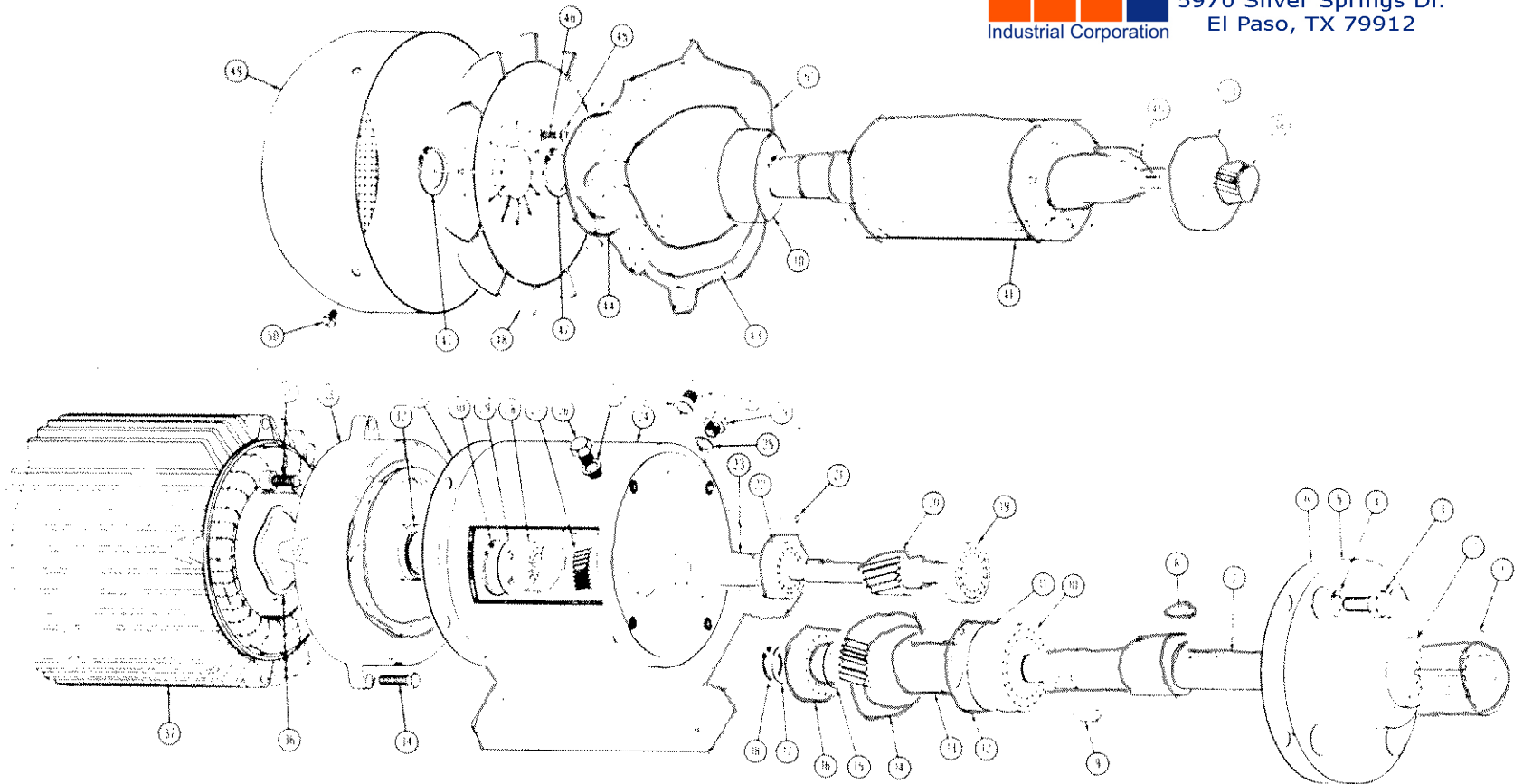

www.cscindustrial.com
 Ph: 1-866-496-7268
 Fax: 1-915-760-4832
 5970 Silver Springs Dr.
 El Paso, TX 79912



1. 4411	Gear, Spur, 21 T.	19. 12823	Bearing, Gearshaft, 6302	37. 12841	Housing and Stator Assy., Motor, 220 V.
2. 12806	Seal, Output Shaft	20. 12824	Gearshaft, Helical, 12 T.	12856	Housing and Stator Assy., Motor, 380-440 V.
3. 12807	Bolt, Hex Hd., Gearcase Cover Att. (4)	21. 12825	Key, Square, 5mmx5mmx14mm	38. 12842	Pinion, Helical, Motor Shaft, 26 T.
4. 12808	Lockwasher, Gearcase Cover Att. (4)	22. 12826	Bearing, Gearshaft, 4203	39. 12843	Screw, Magnetic, Oil Drain
5. 12809	Cover, Gearcase	23. 12827	Spacer, Gear	40. 12844	Key, Square, 3mmx3mmx9mm
6. 12810	Gasket, Gearcase Cover	24. 12828	Housing, Gearcase	41. 12845	Armature Assy., 220 V.
7. 12811	Shaft, Output	25. 12829	Seal (3)	12857	Armature Assy., 380-440 V.
8. 12812	Key, Square, 1/4"x1/4"x3/4"	26. 12830	Screw, Air Vent	42. 12846	Screw, Oil Level Inspection
9. 12813	Key, Rectangular, 8mm x 7mm x 22mm	27. 12831	Gear, Helical, 65 T.	43. 12847	End Bell, Motor
10. 12814	Bearing, Output Shaft & Motor Shaft, 6206 Z (3)	28. 12832	Bearing, Gearshaft, 6301	44. 12848	Retainer, Bearing
11. 12815	Spacer, Bearing	29. 12833	Spacer, Bearing	45. 12849	Washer, Flat, Retainer Att. (3)
12. 12816	Ring, Retaining, Internal	30. 12834	Ring, Retaining, Internal	46. 12850	Screw, Slotted, Retainer Att. (3)
13. 12817	Spacer, Gear	31. 12835	Gasket, Gearcase	47. 12851	Ring, Retaining, Fan (2)
14. 12818	Gear, Helical, 52 T.	32. 12836	Seal, Motor Shaft	48. 12852	Fan, Motor, External
15. 12819	Spacer, Gear	33. 12837	Adapter, Motor Housing	49. 12853	Cover, Motor Fan
16. 12820	Bearing, Output Shaft	34. 12838	Screw, Hex. Hd., Adapter Att. (4)	50. 12854	Screw, Slotted, Cover Att. (4)
17. 12821	Spacer, Bearing	35. 12839	Screw, Soc. Hd., Adapter Att. (4)	51. 12855	Key, Square, 6mmx6mmx20mm
18. 12822	Ring, Retaining, External	36. 12840	Washer, Belleville		



www.cscindustrial.com
Ph: 1-866-496-7268
Fax: 1-915-760-4832
5970 Silver Springs Dr.
El Paso, TX 79912

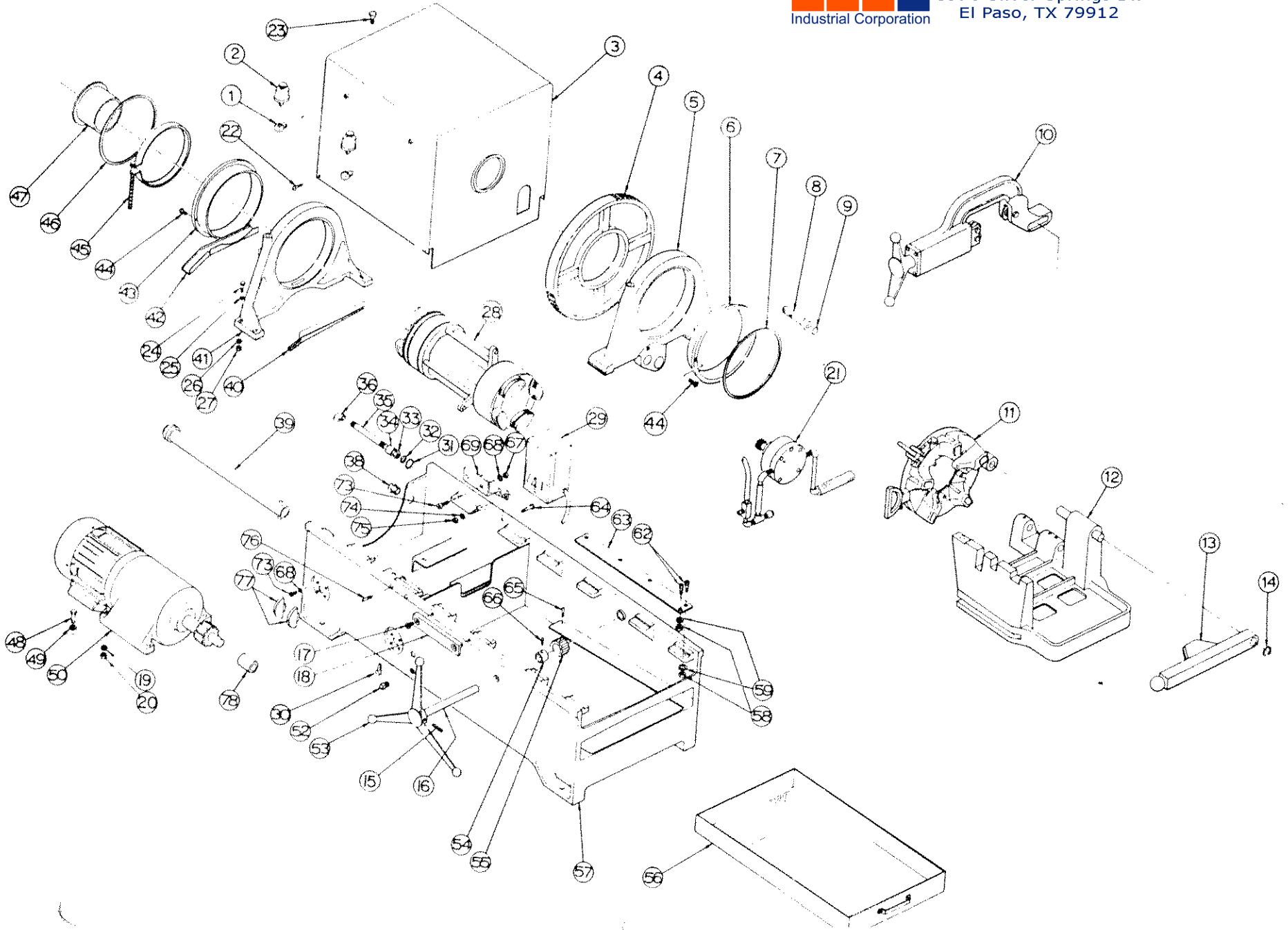

THRED-O-MATIC "33-A" MAIN ASSEMBLY

13394 - Complete foot switch

4217 Gear Spindle
(Gear) regular
structure

1.	4557	Elbow, Oil Cup (2)		41.	12495	Spindle Block, Rear
2.	4558	Oil Cup, Lubricating (2)		42.	4207	Shield, Oil Drip, Rear
3.	12494	Cover, Spindle			NF-503-F	Screw, Self Tapping, Drip Shield Att., 10-20 x 1/2" (2)
4.	12463	Gear, Spur, Spindle, 166 T	(Right & Left)	43.	4080	Bearing, Spindle, Rear
5.	12518	Spindle Block, Front		44.	J-306	Screw, Flat Hd. Mach. Bearing Att., 10-24 x 1/2" (4)
6.	4680	Bearing, Spindle, Front		45.	4250	Brake Band Assembly ¹
7.	YKSA-850	Ring, Spindle Retaining, Front		46.	4218	Ring, Spindle Retaining, Rear
8.	4770	See Oil Line Assy. No. 12528		47.	12548	Adapter, Small Pipe
9.	4566	See Oil Line Assy. No. 12528		48.	A-507	Bolt, Motor Att., 1/2"-13 x 2" (4)
10.	4620	Cutter Assembly, Wheel Type ¹		49.	DA-106-W	Washer, Flat, Motor Att., 1/2" (4)
11.	—	Die Head Assembly ¹		50.	13905	Motor and Transmission Assembly, 220 V., 3 Phase ¹
12.	12802	Carriage Assembly ¹			13906	Motor and Transmission Assembly, 380-440 V., 3 Phase ¹
13.	4760	Reamer Assembly ¹		51.		
14.	Y-5100-100	Ring, Reamer Assembly Retaining		52.	4045	Plug, Pipe, Oil Drain, 1/2"
15.	U-922	Pin, Spring, Handle Att., 1/4" x 2"		53.	12452	Lockwasher, Carriage Feed
16.	12526	Shaft, Carriage Feed		54.	4618	Collar, Carriage Feed Rod
17.	J-1203	Screw, Flat Hd. Mach., 5/16"-18 x 1/2" (2)		55.	4617	Gear, Carriage Pinion
18.	4680	Make-on Bar		56.	12496	Tray, Chip Includes: 4016 Handle K-956-P Screw, Mach., Handle Att., 10-32 x 1/2" (4) B-133 Nut, Handle Att., 10-32 (4) Base Nut, Rail and Carriage Stop Att., 5/16"-18 (9) Lockwasher, Rail and Carriage Stop Att., 5/16" (9)
19.	C-113-M	Lockwasher, Motor Att., 10-32 (4)		57.	12451	
20.	B-105	Nut, Motor Att., 10-32 (4)		58.	B-102	
21.	12497	Pump Assembly ¹ (See also No. 12528 Oil Line Assembly)		59.	C-110-M	
	12497	Pump Assembly, Right & Left ¹ (See also No. 12528 Oil Line Assembly)		60.		
	13064	Pump Assembly, Standard ¹ (See also No. 12528 Oil Line Assembly)		61.		
22.	G-103	Screw, Button Hd. Cap, Spindle Cover Att., 1/4"-20 x 1/2" (4)		62.	F-206	Screw, Soc. Hd. Cap, Rail and Carriage Stop Att., 5/16"-18 x 1" (9)
23.	3404	Thumb screw, Adapter, 3/8"-16 x 1"		63.	12527	Rail, Base (2)
24.	A-408	Screw, Cap, Spindle Block Att., 7/16"-14 x 2 1/4" (8)		64.	E-206	Screw, Flat Hd. Cap, Bracket Att., 5/16"-18 x 1" (2)
25.	DA-205-N	Washer, Flat, Spindle Block Att., 7/16" (8)		65.	P-708-A	Pin, Groove, Gear Att., 3/16" x 1 1/2"
26.	C-112-M	Lockwasher, Spindle Block Att., 7/16" (8)		66.	H-202-D	Set Screw, Collar Att., 5/16"-18 x 5/16"
27.	B-104	Nut, Spindle Block Att., 7/16"-14 (8)		67.	B-132	Nut, Manual Starter Box Att., 10-24 (2)
28.	12789	Spindle Assembly, R — L ¹		68.	CB-107-A	Lockwasher, Switch & Box Att., No. 10 (10)
	4220	Spindle Assembly, Standard ¹		69.	12525	Bracket, Manual Starter Box
29.	12536	Starter, Manual		70.		
30.	12236	See Oil Line Assembly No. 12528		71.		
31.	4572	See Oil Line Assembly No. 12528		72.		
32.	4567	See Oil Line Assembly No. 12528		73.	K-959	Screw, Mach., Switch & Manual Starter Att., No. 10-32 x 3/4" (10)
33.	B-260	See Oil Line Assembly No. 12528		74.	C-110-M	Lockwasher, Bracket Att., 5/16" (2)
34.	4542	See Oil Line Assembly No. 12528		75.	B-102	Nut, Hex., Bracket Att., 5/16"-18 (2)
35.	4540-1	See Oil Line Assembly No. 12528		76.	H-209-D	Setscrew, Spindle Adjusting, 5/16"-18 x 1" (4)
36.	4044	See Oil Line Assembly No. 12528		77.	12803	Handle, Switch (2)
37.				78.	12539	Bearing, Needle, Gearshaft
38.	12556	Bushing, Strain Relief, Power Cord				
39.	4033	Extension Bar Assembly, Breakdown Includes: U-918 Pin, Spring, 1/4" x 1 1/2" 1030-2 Cap, Pipe 4033-1 Bar, Extension				
40.	4206	Shield, Oil Drip, Front				
	NF-503-F	Screw, Self Tapping, Drip Shield Att., 10-24 x 1/2" (2)				

¹See Detailed Assemblies



www.cscindustrial.com
Ph: 1-866-496-7268
Fax: 1-915-760-4832
5970 Silver Springs Dr.
El Paso, TX 79912

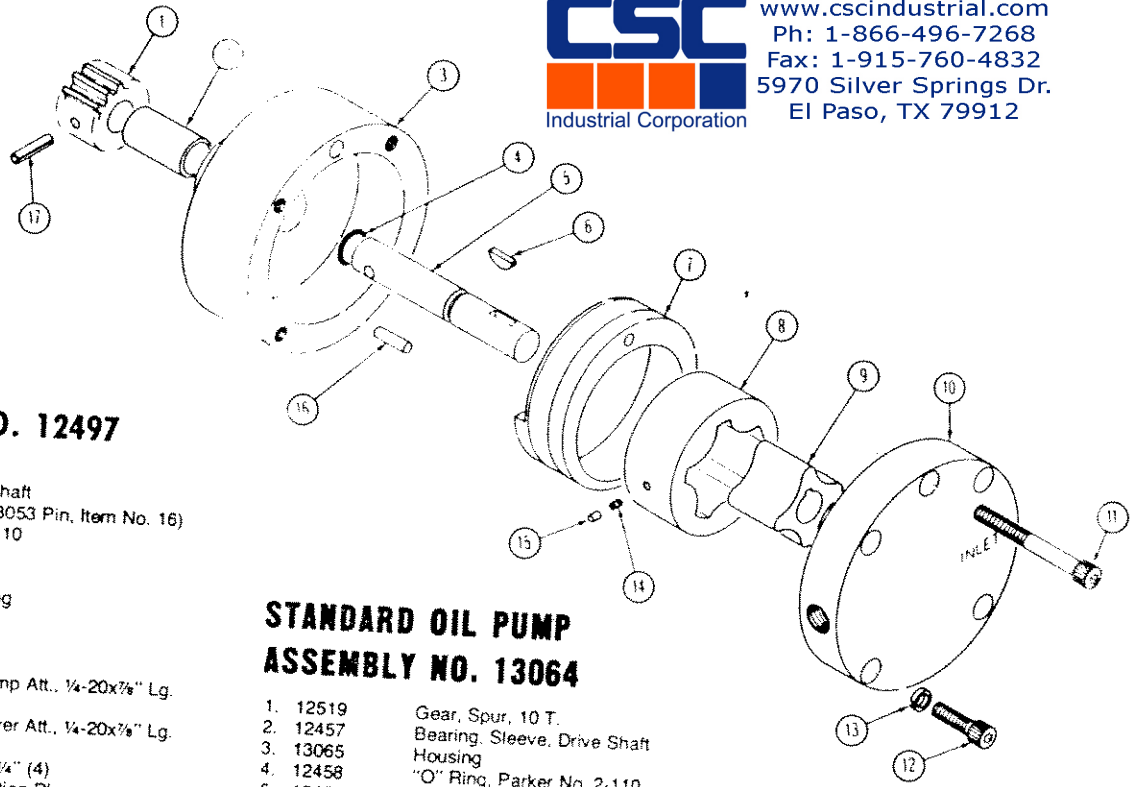

**STANDARD OIL PUMP
ASSEMBLY NO. 13064**

- | | | |
|-----|----------|--|
| 1. | 12519 | Gear, Spur, 10 T. |
| 2. | 12457 | Bearing, Sleeve, Drive Shaft |
| 3. | 13065 | Housing |
| 4. | 12458 | "O" Ring, Parker No. 2-110 |
| 5. | 12454 | Shaft, Drive |
| 6. | W-404 | Key, Woodruff, 1/8"x1/2" |
| 7. | | Not in Standard Pump |
| 8. | *12456-2 | Gerotor, Outer |
| 9. | *12456-1 | Gerotor, Inner |
| 10. | 12455 | Cover, Oil Pump Housing |
| 11. | F-112-SL | Screw, Soc. Hd. Cap. Pump Att., 1/4-20x7/8" Lg. w/Nylock |
| 12. | K-1108 | Screw, Soc. Hd. Cap. Cover Att., 1/4-20x7/8" Long (4) |
| 13. | C-109HC | Lockwasher, High Collar, 1/4" (4) |
| 14. | 12280 | Spring, Compression, Friction Plunger |
| 15. | 12275 | Plunger, Friction |
| 16. | P-703-B | Pin, 3/16x3/4" Lg. (See Item No. 3) |
| 17. | U-711 | Pin, Spring, 3/16x3/4" Long |

Note: Items 8 & 9 are sold as a Set (No. 13066) Only

**RIGHT & LEFT
OIL PUMP ASSEMBLY NO. 12497**

- | | | |
|-----|----------|--|
| 1. | 12519 | Gear, Spur, 10 T. |
| 2. | 12457 | Bearing, Sleeve, Drive Shaft |
| 3. | 12453 | Housing (Includes No. 13053 Pin, Item No. 16) |
| 4. | 12458 | "O" Ring, Parker No. 2-110 |
| 5. | 12454 | Shaft, Drive |
| 6. | W-404 | Key, Woodruff, 1/8"x1/2" |
| 7. | 12801* | Ring, Eccentric, Reversing |
| 8. | 12456-2* | Gerotor, Outer |
| 9. | 12456-1* | Gerotor, Inner |
| 10. | 12455 | Cover, Oil Pump Housing |
| 11. | F-112-SL | Screw, Soc. Hd. Cap. Pump Att., 1/4-20x7/8" Lg. w/Nylock |
| 12. | K-1108 | Screw, Soc. Hd. Cap. Cover Att., 1/4-20x7/8" Long (4) |
| 13. | C-109HC | Lockwasher, High Collar, 1/4" (4) |
| 14. | 12280 | Spring, Compression, Friction Plunger |
| 15. | 12275 | Plunger, Friction |
| 16. | P-703-B | Pin, 3/16x3/4" Lg. (See Item No. 3) |
| 17. | U-711 | Pin, Spring, 3/16x3/4" Long |

Note: Items No. 7, 8, & 9 are sold as a set (No. 12456) only

OIL LINE ASSEMBLY NO. 12528

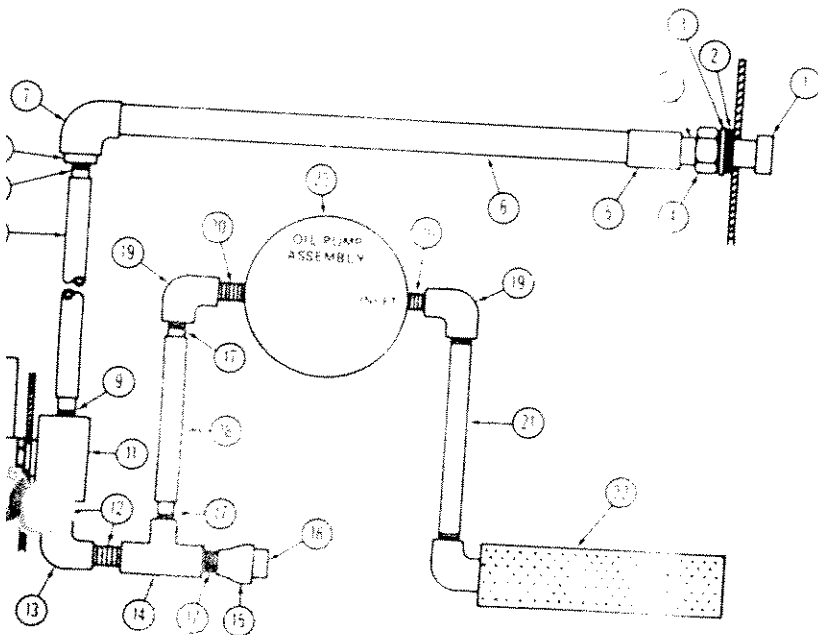

- | | | |
|-----|-----------|---|
| 1. | 4770 | Fitting, Oil Tube, Telescopic |
| 2. | 4566 | "O" Ring, Inside |
| | 4572 | "O" Ring, Outside |
| 3. | 4567 | Washer, Flat |
| 4. | B-260 | Nut, Jam, Hex, 7/8"-14 |
| 5. | 4542 | Coupling, Pipe, 1/2" |
| 6. | 4540-1 | Housing, Oil Tube, Telescopic |
| 7. | 4044 | Elbow, Pipe, 1/2" |
| 8. | 4569 | Reducer, Pipe, 1/2" to 3/8" |
| 9. | 12233 | Nipple, Pipe, Thd. One End, 3/8"x2" Lg. (2) |
| 10. | 15351-37 | Hose, 3/4" I.D. x 37" Lg. |
| 11. | 12236 | Valve, Oil Control |
| 12. | 12792 | Nipple, Pipe, Close, 3/8"x1 1/4" Lg. (3) |
| 13. | 12793 | Elbow, Pipe, 3/8"x90° |
| 14. | 12794 | Tee, Pipe, 3/8"x1/4"x3/8" |
| 15. | 12795 | Reducer, Bell, Pipe, 1/2" to 3/8" |
| 16. | 4630 | Valve Assembly, Pressure Relief includes:
4631 Body
4632 Spring
4633 Ball
4638 Screw, Adjusting |
| 17. | 12796 | Nipple, Pipe, Thd. One End, 1/4"x2" Lg. (2) |
| 18. | 12797-6 | Hose, 1/2" I.D. x 6" Lg. |
| 19. | 12798 | Elbow, Pipe, 1/4"x90° (2) |
| 20. | 12799 | Nipple, Pipe, Close, 1/4"x2" Lg. (2) |
| 21. | 12800 | Pipe, Threaded, 1/4"x7" Lg. |
| 22. | 12791 | Strainer Assembly |
| 23. | 12497 | Pump Assembly |
| | Not Shown | 4514-10 Clamp, Hose (4) |

WHEEL TYPE CUTTER ASSEMBLY NO. 4620
1/2" - 4" RANGE

35-A
 THREE-D-MATH

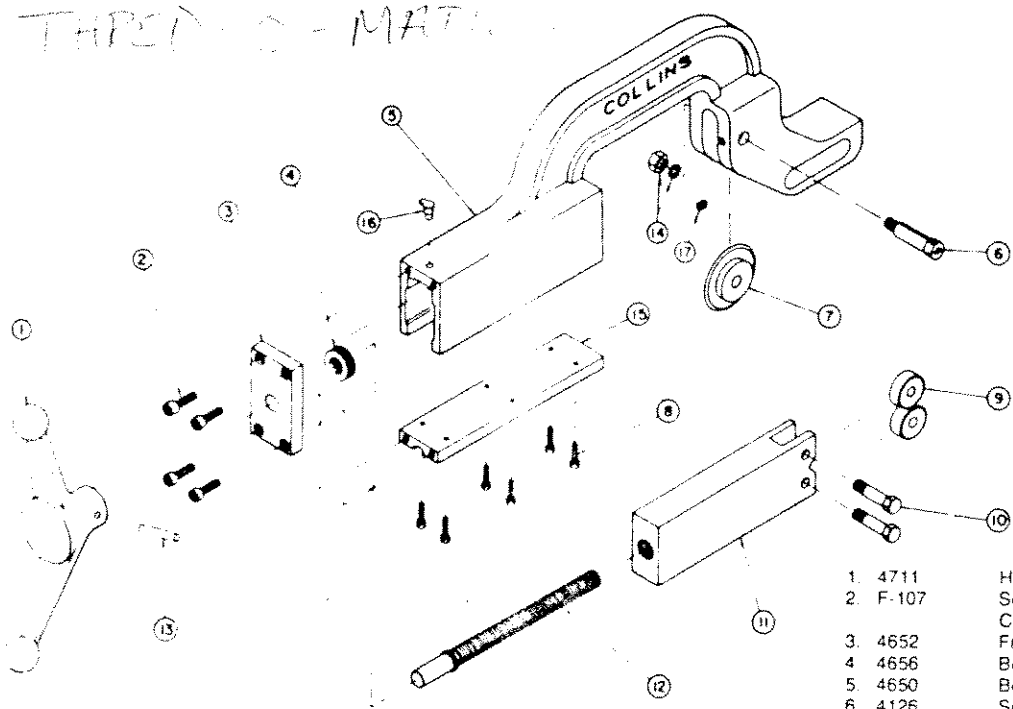

- 1. 4711 Handle, Cutter
- 2. F-107 Screw, Front Vlate Att., 1/4"-20x1" Soc. Hd. Cap (4)
- 3. 4652 Front Plate
- 4. 4656 Bearing, Thrust
- 5. 4650 Body, Cutter
- 6. 4125 Screw, Cutter Wheel
- 7. 4121 Wheel, Cutter
- 8. F-063 Screw, Bottom Plate Att., 10 32x3/4" Soc. Hd. Cap (6)
- 9. 4117 Roller, Cutter (2)
- 10. 1124 Screw, Roller (2)
- 11. 4651 Roller Block
- 12. 4103 Screw, Cutter
- 13. P-9061-A Pin, Handle Att., 1/4"x1 1/8" Grooved
- 14. B-103 Nut, Cutter Wheel Att., 3/8"-16 Hex
- C-111-M Lock Washer, Cutter Wheel Att., 3/8"
- 15. 4653 Bottom Plate
- 16. 1023-22 Oil Cup
- 17. H-104-D Setscrew, 1/4"-20x3/8"

~~CONE REAMER ASSEMBLY NO. 10060~~ → 15448

"NEW PART #"

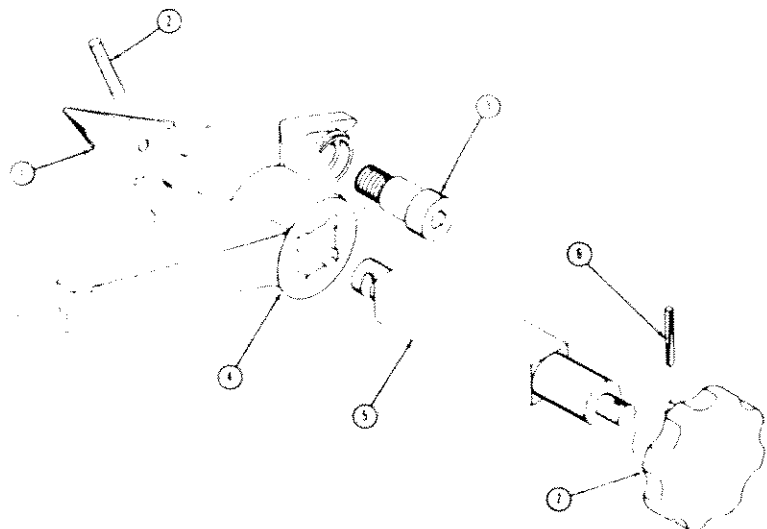

- 1. 13212 Cone Reamer
- 2. 1654-3 Cone Reamer Attaching Pin
- *3. F-607 Screw, Soc. Hd. Cap, 3/8"-11x1 1/2"
- 2139-1 Spacer
- 4. 10065 Cone Reamer Holder
- 5. 1659-1 Cone Reamer Extension
- 6. P-707-A Grooved Pin 3 16"x1 1/4"
- 7. 1652 Cone Reamer Knob

*Not included in Assembly. Order Separate

STANDARD SPINDLE ASSEMBLY NO. 4220

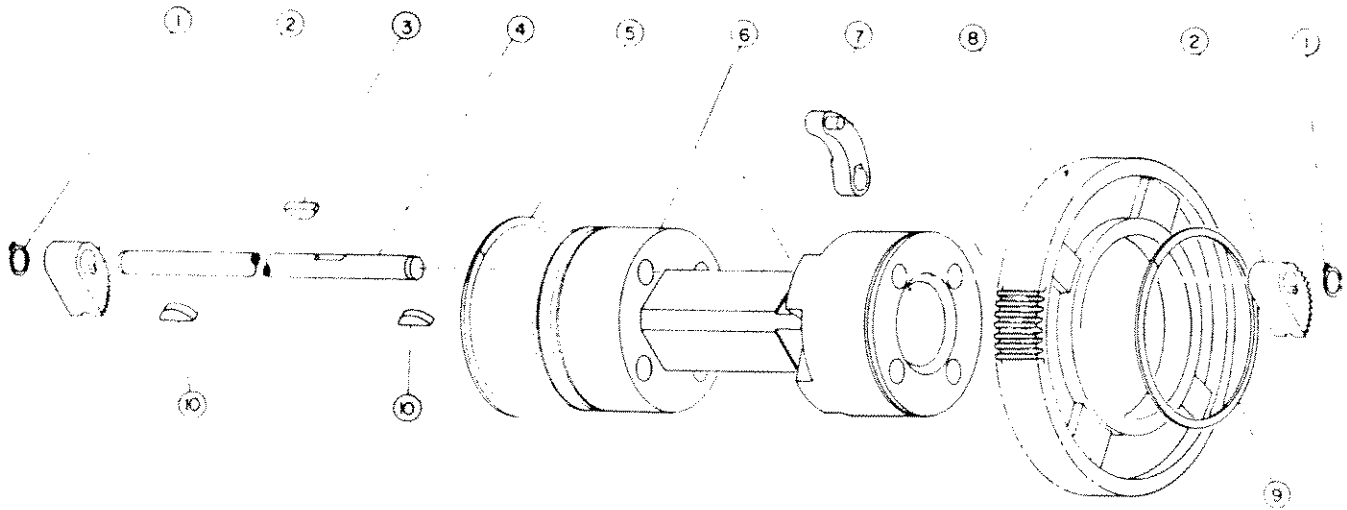

- | | | | |
|---------------|---------------------------------------|-------------|-------------------------------------|
| 1. Y-5100-100 | Ring, Jaw Retaining (8) | 6. 4225 | Spindle |
| 2. 4214-1 | Jaw, Pipe (8) | 7. 4212 | Lever and Pin Assy., Jaw (4) |
| 3. W-810 | Key, Woodruff, Jaw Lever, 1/4"x1 1/4" | 8. 4217 | Gear, Spindle |
| 4. 4211 | Shaft, Jaw (4) | 9. YKSA-850 | Ring, Spindle Retaining, Front |
| 5. YKSA-850 | Ring, Spindle Retaining Rear | 10. W-810 | Key, Woodruff, Jaw, 1/4"x1 1/4" (8) |

*Order No. 12461 & 12462 for Bolt Threading (See Below)

RIGHT AND LEFT SPINDLE ASSEMBLY NO. 12789

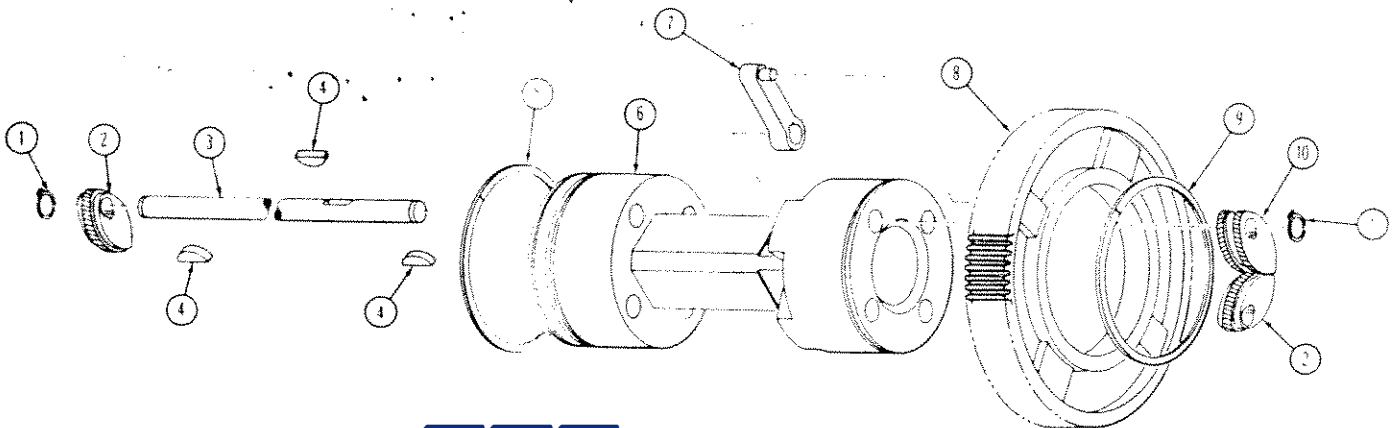

www.cscindustrial.com
 Ph: 1-866-496-7268
 Fax: 1-915-760-4832
 5970 Silver Springs Dr.
 El Paso, TX 79912

- | | | | |
|---------------|---------------------------------|-------------|-----------------------------|
| 1. Y-5100-100 | Ring, Jaw Retaining (8) | 7. 12790 | Lever & Pin Assy., Jaw |
| 2. 12461 | Jaw, Reversible, Single (4) | 12464 | Lever |
| 3. 12529 | Shaft, Jaw (4) | 4212-2 | Pin |
| 4. W-810 | Key, Woodruff, 1/4"x1 1/4" (12) | 8. 12463 | Gear, Spur, Spindle |
| 5. YKSA-850 | Ring, Spindle Retaining | 9. YKSA-850 | Ring, Spindle Retaining |
| 6. 4225 | Spindle | 10. 12462 | Jaw, Reversible, Double (4) |

SNAP-O-MATIC DIE HEAD ASSEMBLIES 2½" - 4"

- | | | |
|----|---------|---|
| 1 | 4905 | Retainer, Scroll Plate, 3½"-4" |
| | 4906 | Retainer, Scroll Plate, 2½"-3" |
| 2 | 6601 | Scroll Plate |
| 3 | 6602 | Lever, Operating includes 0-406 Dowel Pin |
| 4 | A-102 | Screw, Selector Plate Att., ¼"-20x½" Hex Hd. Cap (4) |
| 5 | 6639 | Stop, Scroll Plate |
| | F-103 | Screw, Stop Att., ¼"-20x½" Soc. Hd. Cap (2) |
| 6 | — | — |
| 7 | — | Set of (5) Dies, Specify size and type (e.g. 2½" and 3" N.P.T.) |
| 8 | 4947 | Housing, Die Head, 2½"-3" |
| | 4948 | Housing, Die Head, 3½"-4" |
| 9 | 12235 | Plug, Expansion |
| 10 | O-408 | Dowel Pin, Operating Lever |
| 11 | 6608-1 | Selector Plate, 3½" |
| | 6608-2 | Selector Plate, 4" |
| | 6609-1 | Selector Plate, 2½" |
| | 6609-2 | Selector Plate, 3" |
| 12 | H-503-D | Set Screw, Die Head Centering, ½"-13x1½" Hex. Socket |
| 13 | A-504-P | Screw, Handle Att., Hex Hd. Cap, ½"-13x1¼" |
| | C-113-M | Lock Washer, Handle Att., ½" |
| 14 | A-505-P | Screw, Die Head Centering, ½"-13x1½" Hex Hd. Cap |
| 15 | 6950 | Handle, Die Head |
| 16 | F-208 | Screw, Retainer Plate Att., 5/16-18x1½" (5) |

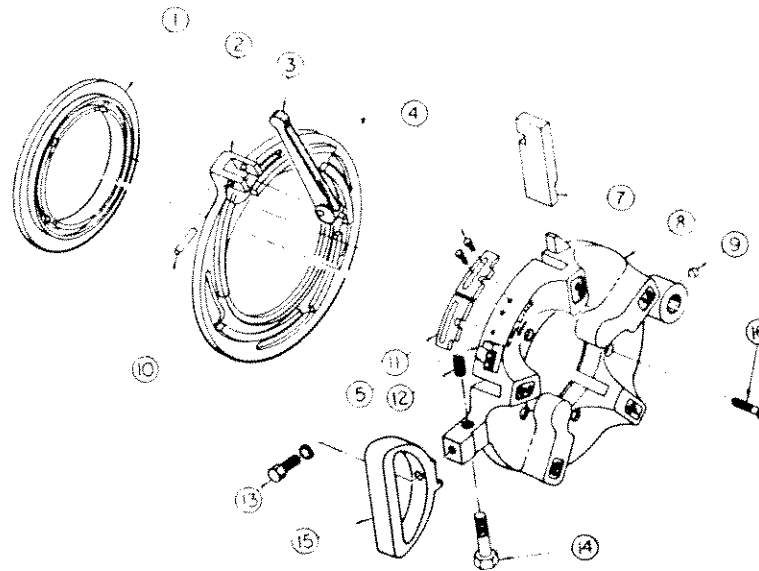

SNAP-O-MATIC DIE HEAD ASSEMBLIES 1/8" - 2"

DUAL SNAP-O-MATIC DIE HEADS: ½", ¾" & ¾", 1½" & 1½", 1" & 1¼", 1½" & 2"
 QUAD SNAP-O-MATIC DIE HEAD: 1" - 2"

- | | | |
|----|---------|--|
| 1 | F-053 | Die Head Soc. Hd. Cap Screw, 10-24x¾" (4) |
| | O-107HC | Lockwasher, Hi Collar, No. 10 |
| 2 | 1433 | 1"-2" Retainer Plate |
| | 1673 | ½"-¾" Retainer Plate |
| 3 | 1632 | 1"-2" Scroll Plate |
| | 1642 | ½"-¾" Scroll Plate |
| 4 | 1633 | Operating Lever |
| 5 | O-406 | Operating Lever Pivot Dowel Pin, 5/16"x1½" |
| 6 | 1634-1 | 1"-1¼"-1½" Selector Plate |
| | 1635-1 | 1" Selector Plate |
| | 1635-2 | 1¼" Selector Plate |
| | 1636-1 | 1½" Selector Plate |
| | 1636-2 | 2" Selector Plate |
| | 1644-1 | ½" Selector Plate |
| | 1644-2 | ¾" Selector Plate |
| | 1645 | ¼" & ½" Selector Plate |
| | 1646 | ¾" Selector Plate |
| 7 | G-103 | Selector Plate Att. Button Hd. Cap Screw ¼"-20x½" (4) |
| 8 | F-107 | Scroll Plate Stop Soc. Hd. Cap Screw, ¼"-20x1" |
| 9 | 13113 | Scroll Plate Spacer |
| 10 | 1631 | 1"-2" Die Head Housing |
| | 1641 | ½"-¾" Die Head Housing |
| 16 | 1431-1 | Die Head Pin |
| 17 | — | Set of (4) Dies, Specify Size and Type (e.g. 1½" N.P.T.) |
| 18 | 13385 | Ball |
| 19 | 12220 | Spring |
| 20 | 12135 | Expansion Plug |

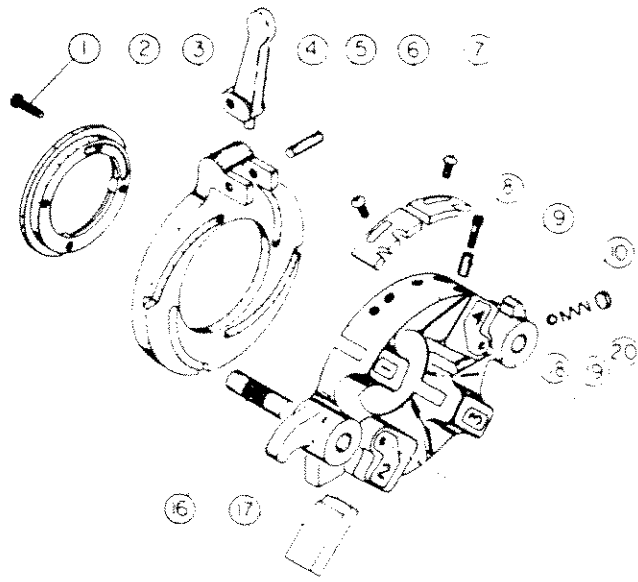

www.cscindustrial.com
 Ph: 1-866-496-7268
 Fax: 1-915-760-4832
 5970 Silver Springs Dr.
 El Paso, TX 79912

UNIQUAD DIE HEAD ASSEMBLY 1/8" - 2"

- | | | |
|-----|---------|---|
| 1. | 1433 | Retainer Plate |
| 2. | 1432 | Uniquad Scroll Plate |
| 3. | 1437 | Operating Lever |
| 4. | O-406 | Operating Lever Stop Dowel Pin, 5/16"x1 1/4" |
| 5. | O-702 | Operating Lever Pivot Dowel Pin, 1/2"x1 1/4" |
| 6. | 2183 | Uniquad Die Head Link |
| 7. | 2182 | Uniquad Die Head Pivot Screw |
| 8. | D-204-N | Pivot Screw Flat Washer, 3/8" |
| 9. | 1436 | Scroll Plate Locking Lever |
| 10. | | Uniquad Dies: Specify Size and Type (e.g. 1/2" & 1/4" N.P.T.) |
| 11. | 1431 | Uniquad Die Head Housing |
| 12. | 1431-1 | Die Head Pin |
| 13. | F-053 | Die Head Sec. Hd. Cap Screw, 10-24x1 1/4" (4) |
| | C-107HC | Lockwasher, Hi Comp. No. 10 |
| 14. | 13385 | Ball |
| 15. | 12220 | Spring |
| 16. | 12135 | Expansion Plug |

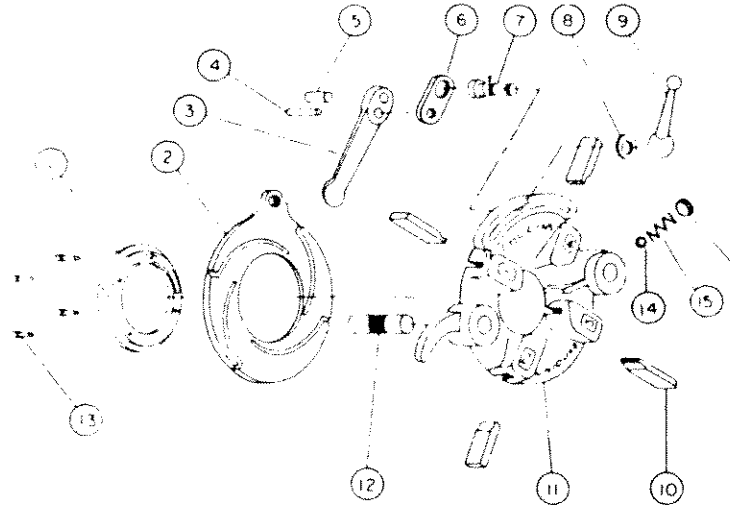

BRAKE BAND ASSEMBLY NO. 12580

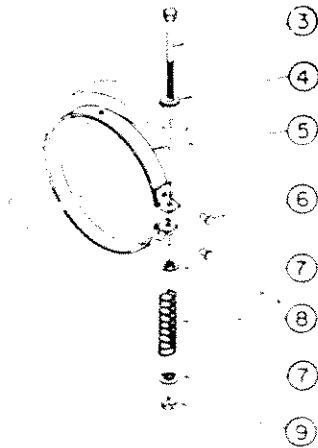

- | | | |
|----|----------|--|
| 3. | 4261-1 | Bolt, Adjustment, 3/8"-16x7 1/2" Hex Hd. |
| 4. | DA-104-W | Flat Washer, Adjustment Bolt, 3/8" |
| 5. | 12581 | Shoe & Lining Assembly |
| 6. | 4255 | Rivet, Reinforcement (2) |
| 7. | DA-104-W | Flat Washer, Spring (2) |
| 8. | 4260 | Spring, Brake Band |
| 9. | B-303 | Nut, Adjustment, 3/8"-16 Hex |

BLADE REAMER ASSEMBLY NO. 4760 2 1/2" - 4" RANGE

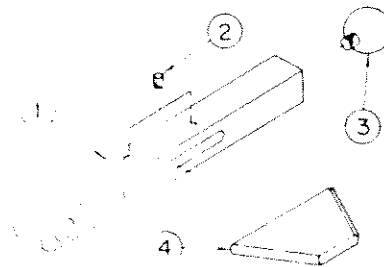

- | | | |
|----|---------|--|
| 1. | 4816 | Holder, Reamer |
| 2. | H-305-D | Set Screw, Reamer Att., 3/8"-16x1 1/2" (2) |
| 3. | 4943-1 | Handle, Reamer |
| | H-508-D | Set Screw, Handle Att., 1/2"-13x1 1/4" |
| 4. | 12237 | Reamer, Inside |



www.cscindustrial.com
Ph: 1-866-496-7268
Fax: 1-915-760-4832
5970 Silver Springs Dr.
El Paso, TX 79912

CARRIAGE ASSEMBLY NO. 12802

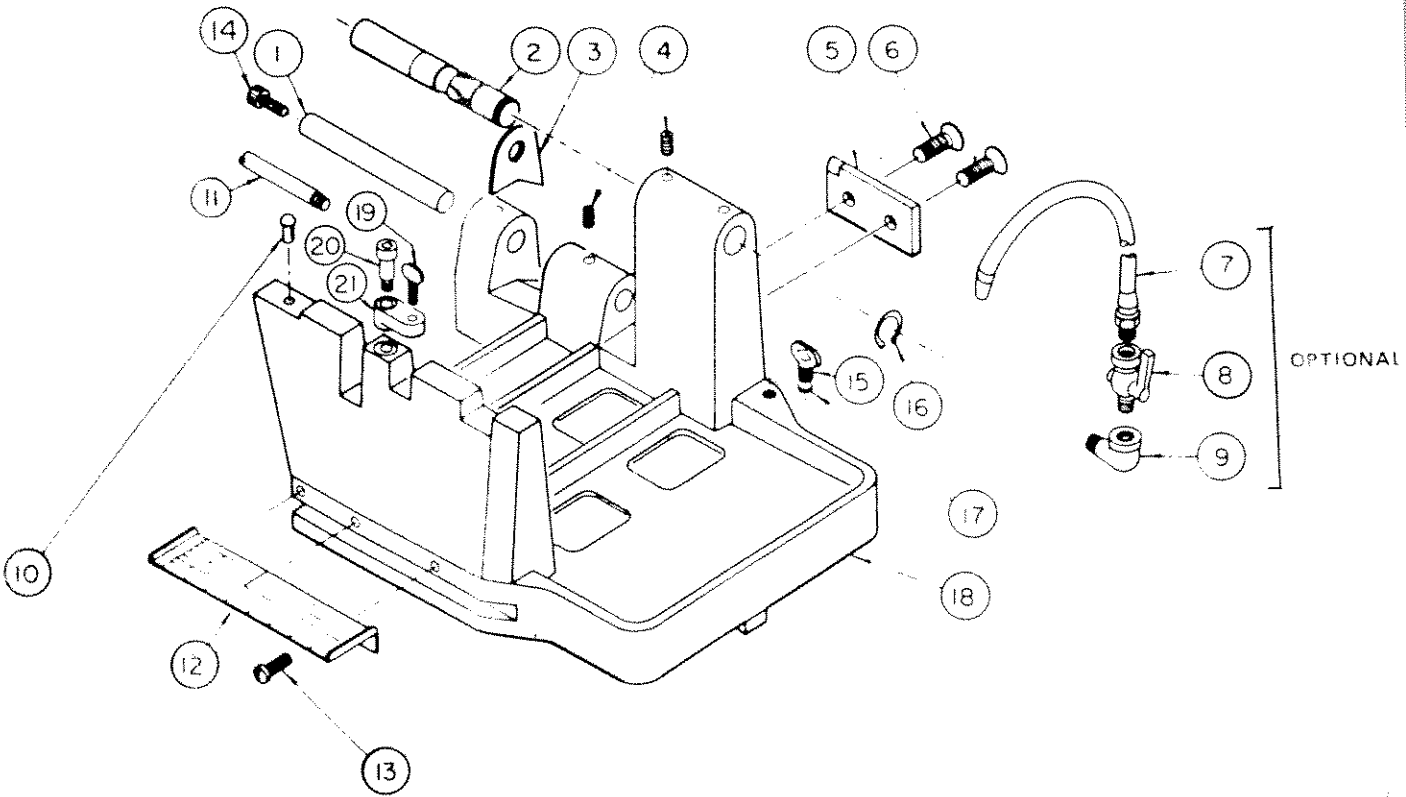

- | | | | |
|------------|---|----------------|--|
| 1. 4654-2 | Pin, Cutter Pivot | 11. 4563 | Tube, Telescopic, Coolant |
| 2. 4917 | Pin, Reamer and Die Head | 14. F-204 | Screw, Pivot Pin, 5/16"-18x3/4" Soc. Hd. Cap |
| 3. 4919 | Wear Plate, Cutter (2) | 15. 3404 | Thumbscrew, Carriage Locking, 3/8"-16x1" |
| 4. H-205-D | Set Screw, Pin Retaining, 5/16"-18x1/2" Hex. Socket (4) | 16. Y-5100-100 | Ring, Retaining, Blade Reamer |
| 5. 4914 | Stop, Die Head | 17. 6732 | Wear Button |
| 6. E-206 | Screw, Stop Att., 5/16"-18x1" Flat Head, Cap (2) | 18. 4916 | Carriage |
| 7. 4657 | Spout, Flexible, Coolant | *19. 12870 | Thumbscrew, 1/4-20x7/8" Lg. |
| 8. 4658 | Valve, Coolant Spout | *20. I-303 | Shoulder Screw, 3/8"x3/8" Lg. |
| 9. 4556 | Elbow, Pipe | *21. 12542 | Retainer, Die Head |
| 10. 4655 | Pin, Cutter Rest | — 12460 | Shield, Oil Drip (Not Shown) |

*Only on Right & Left Machines for Left Hand Threading.

SMALL DIE HEAD ADAPTER ASSEMBLY NO. 12372

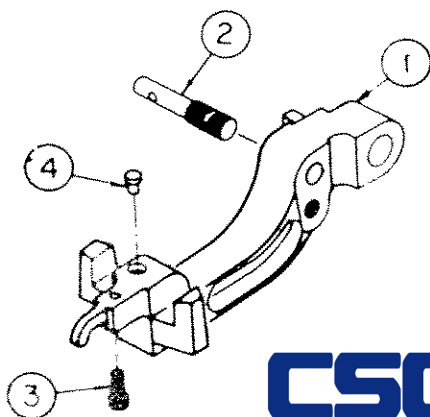

- | | |
|----------|---|
| 1. 12239 | Adapter |
| 2. 12886 | Pin, Die Head and Reamer |
| 3. F-206 | Screw, Adapter Centering 5/16"-18x1" Soc. Hd. Cap |
| 4. 1572 | Pin, Die Head Stop |



www.cscindustrial.com
 Ph: 1-866-496-7268
 Fax: 1-915-760-4832
 5970 Silver Springs Dr.
 El Paso, TX 79912

GROOVER HEAD ASSEMBLIES 2 1/2" - 4" RANGE

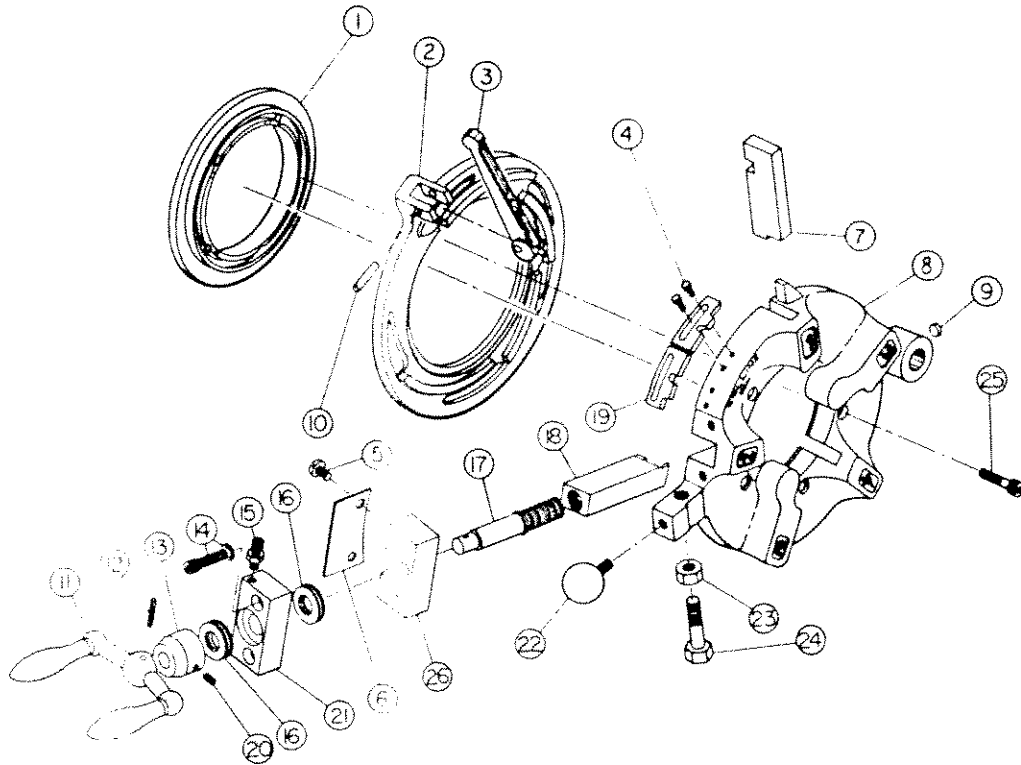

1	4905	Retainer, Scroll Plate	17	12227	Screw, Feed
2	12122	Scroll Plate, 2 1/2"-4"	18	12229-40	Grooving Tool, Sch. 40 Pipe, 1/2"-6"
3	6602	Lever, Operating includes O-406 Dowel Pin		12229-80	Grooving Tool, Sch. 80 Pipe, 2 1/2"-6"
4	A-102	Screw, 1/4"-20x1 1/2" Hex Hd. Cap (4)		12224	Beveling Tool, 37 1/2 degrees, 2 1/2"-6"
5	L-1100	Screw, Round Head Mach. 1/4-20x1 1/4" (2)		12213	Double Bevel Tool, 37 1/2 degrees, 2 1/2"-6"
6	12228	Cover, Die Slot Extension		12268	Double Bevel Tool, 45 degrees, 2 1/2"-6"
7	12101	Die, Centering, 2 1/2"-3" (4)		12218	Saran Tool, 2 1/2"-6"
	12104	Die, Centering, 3 1/2"-4" (4)	19.	6609-1	Selector Plate, 2 1/2"
8	12090	Housing, Groover		6609-1	Selector Plate, 3"
9	12235	Plug, Expansion		6608-1	Selector Plate, 3 1/2"
10	O-408	Dowel Pin, 5/11"x1 1/4"		6608-2	Selector Plate, 4"
11	12215	Handle, Feed Screw	20.	H-103-A	Set Screw, 1/4"-20x5/16"
12	P-706-A	Grooved Pin, 3/16"x1"	21.	12094	Bearing Block
13	12097	Indicator, Groove Depth	22.	4943-1	Handle, Die Head
14	F-209	Screw, Soc. Hd. Cap, 5/16"-18x1 1/4" (2)		H-508-D	Set Screw, 1/2"-13x1 1/4"
	C-110-M	Lock Washer, 5/16" (2)	23.	B-105-P	Nut, 1/2"-13 Hex
15	F-105	Screw, Soc. Hd. Cap, 1/4-20x3/4"	24.	A-505-P	Screw, 1/2"-13x1 1/2" Hex Hd. Cap
	B-101	Nut, Std. Hex, 1/4-20	25	F-208	Screw, 5/16"-18x1 1/2" Soc. Hd. Cap (5)
16	12096	Bearing Thrust (2)	26.	12226	Extension, Die Slot



www.cscindustrial.com
 Ph: 1-866-496-7268
 Fax: 1-915-760-4832
 5970 Silver Springs Dr.
 El Paso, TX 79912

Snap-O-Matic Die Head Assemblies 1/8"-2"

Dual Snap-O-Matic Die Heads: 1/8", 1/4", & 3/8": 1/2" & 3/4"; 1" & 1 1/4"; 1 1/2" & 2"
 Quad Snap-O-Matic Die Head: 1"-2"

Item	Part No.	Description
1.	F-053	Die Head Soc. Hd. Cap Screw, #10-24 x 3/4" (4)
2.	C-107H	Lockwasher, Hi Collar, No. 10
3.	1433	1"-2" Retainer Plate
	1673	1/8"-3/4" Retainer Plate
4.	1632	1"-2" Scroll Plate
	1642	1/8"-3/4" Scroll Plate
5.	1633	Operating Lever
	O-406	Operating Lever Pivot Dowel Pin, 5/16" x 1 1/4"
6.	1634-1	1"-1 1/4"-1 1/2" Selector Plate
	1635-1	1" Selector Plate
	1635-2	1 1/4" Selector Plate
	1636-1	1 1/2" Selector Plate
	1636-2	2" Selector Plate
	1644-1	1/2" Selector Plate
	1644-2	3/4" Selector Plate
	1645	1/4" & 3/8" Selector Plate
	1646	1/2" Selector Plate
7.	G-103	Selector Plate Att. Button Hd. Cap Screw, 1/4"-20 x 1/2" (4)
8.	F-107	Scroll Plate Stop Soc. Hd. Cap. SCREW, 1/4"-20 x 1
9.	13113	Scroll Plate Stop
10.	1631	1"-2" Die Head Housing
	1641	1/8"-1/4" Die Head Housing
16.	1431-1	Die Head Pin
17.	—	Set of (4) Dies, specify size and type (ex., 1/2" NPT)(See Die Tables)
18.	B-1044-3	Ball
19.	12220	Spring
20.	12135	Expansion Plug

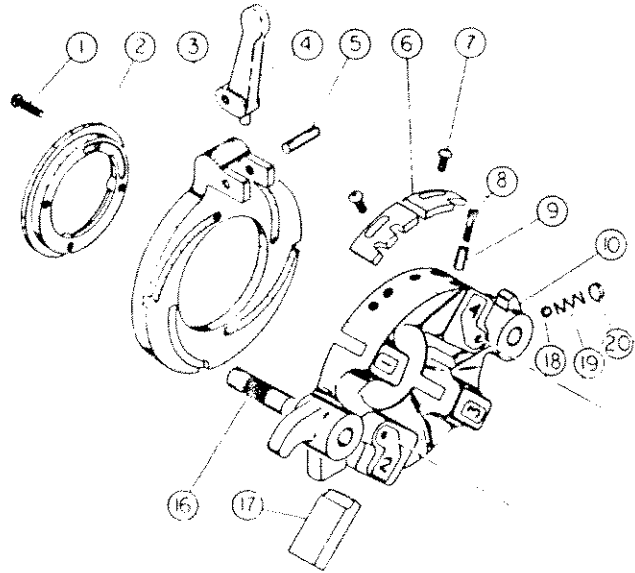

Uniquad Die Head Assembly 1/8"-2"

Item	Part No.	Description
1.	1433	Retainer Plate
2.	1432	Uniquad Scroll Plate
3.	1437	Operating Lever
4.	O-407	Operating Lever Stop Dowel Pin, 5/16" x 1 1/2"
5.	O-702	Operating Lever Pivot Dowel Pin, 1/2" x 1 1/4"
6.	2183	Uniquad Die Head Link
7.	2182	Uniquad Die Head Pivot Screw
8.	D-204	Pivot Screw Flat Washer, 3/8"
9.	1436	Scroll Plate Locking Lever
10.	—	Uniquad Dies, specify size and type (ex., 1/2" & 3/4" NPT)(See Die Tables)
11.	1431	Uniquad Die Head Housing
12.	1431-1	Die Head Pin
13.	F-053	Die Head Soc. Hd. Cap Screw, 10"-24" x 3/4" NPT
14.	B-1044-3	Ball
15.	12220	Spring
16.	12135	Expansion Plug

